

# FLUID POWER Design Data Sheet



Revised Sheet 70 - Womack Design Data File

## ROTARY-TYPE PRESSURE INTENSIFIERS

A pressure intensifier is a device which accepts a flow of oil (or other fluid) at a relatively low pressure and converts it to a higher pressure. The rate of flow is reduced in the same proportion that the pressure is amplified. It is a constant horsepower device; that is, the inlet and outlet operate at the same horsepower (except for internal friction losses in the intensifier). A given amount of power flowing into the inlet comes out at the same horsepower (minus losses) but at a different ratio of pressure to flow rate.

There are several devices available for amplifying pressure. One very common type is described in **Design Data Sheet 69**. It is a reciprocating piston-type unit using a large area piston on the inlet coupled with a smaller area piston on the outlet. The pressure obtained on the outlet is a direct function of the ratio of areas of the two pistons. This type unit usually operates from shop air pressure driving the inlet piston and pumps liquid to an intensified pressure. However, models are available using liquid or gas on the inlet and delivering liquid or gas from the outlet. One possible disadvantage of the piston intensifier is that the outlet flow pulsates as the piston strokes. When an intensifier is being considered, we suggest a study of **Design Data Sheet 69**.

In this issue we are describing another type of intensifier with characteristics which might make it more suitable for certain kinds of applications. It is essentially the same unit as used for a rotary flow divider. Its use as a flow divider is described in **Design Data Sheet 31**. We suggest a review of that sheet in connection with the present sheet.

In the rotary flow divider (or intensifier), two or more gear-type pumps (or motors) are contained within an assembly. **Figure 1** shows a unit with two sections. The shafts are not brought out of the case; they are internally coupled together. When used as a flow divider, fluid entering the common inlet port is divided into two streams of fluid with volumes in

proportion to the displacement of the two gear sections. For example, a flow of 20 GPM at 1,500 PSI can be divided into two flows of 10 GPM each at a pressure of 1,500 PSI. When used as an intensifier, one of the outlet ports is connected directly to tank with minimum restriction. An amplified pressure is then available on the other outlet. For example, a 20 GPM flow at 1,500 PSI can be intensified to 3,000 PSI but at only 10 GPM flow.



**Figure 1.** Two-Section, Rotary-Type, Pressure Intensifier.

In comparing the piston-type with the rotary type, rotary intensifiers are limited to a modest increase of pressure, usually to no higher than 3,000 PSI, but they are capable of delivering a much higher flow and deliver it with minimum ripple, no more than usual from a gear pump.

Piston intensifiers usually work in the main branch of the hydraulic system, boosting pump pressure to a higher level when the pump has reached its limit as established by the relief valve. Rotary intensifiers are seldom used in the main circuit of a hydraulic system. A better arrangement for a single-branch system is to purchase a larger pump which will develop the maximum pressure required.

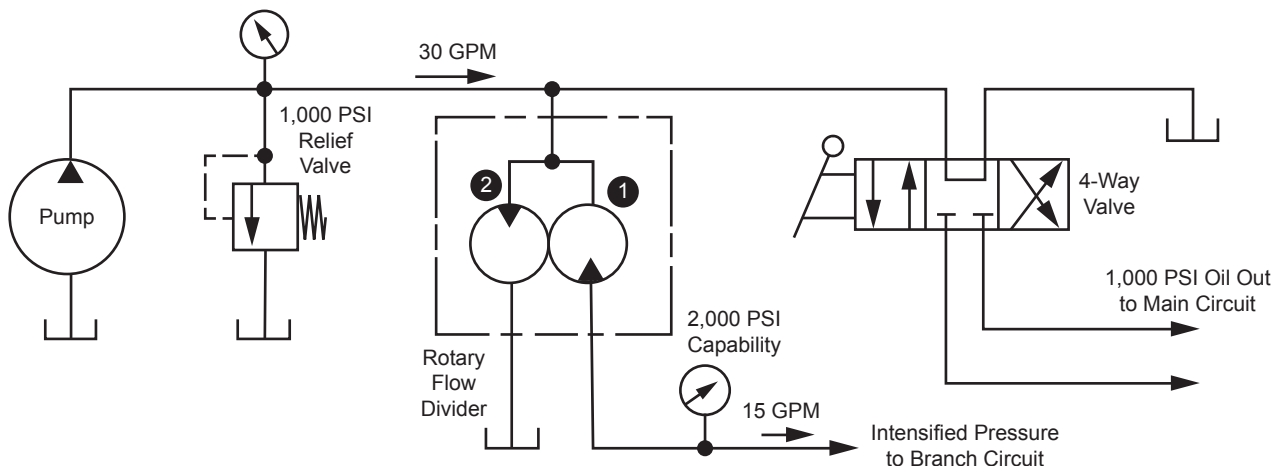

**Figure 2.** Intensified Pressure in One Branch of a Hydraulic Circuit.

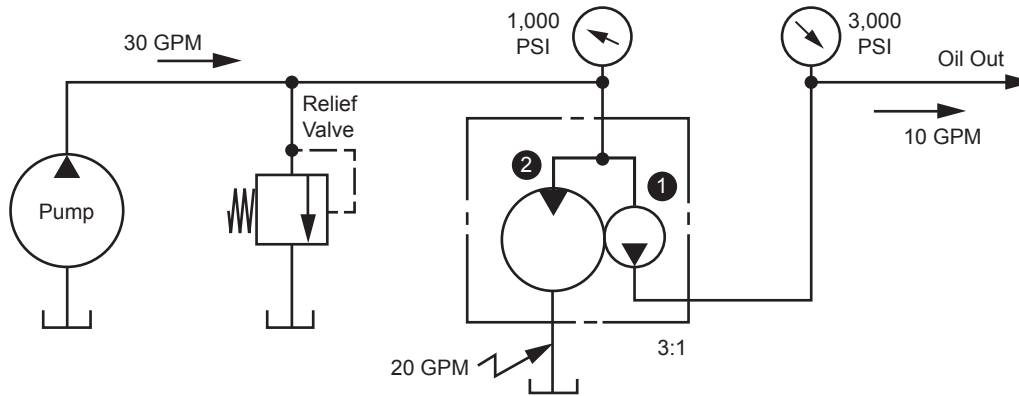

**Figure 3.** Using a Rotary Pressure Intensifier with Unequal Sections.

The losses in a gear-type intensifier are about 15 to 20%, the same as for a comparable gear pump at the same pressure.

While piston-type intensifiers are built to operate on many combinations of fluids, rotary intensifiers are strictly limited to hydraulic fluids.

**FIGURE 2.** This diagram illustrates the operation of a 2-section intensifier having equal displacements in both sections. The pump is delivering 30 GPM and its relief valve is set for a maximum of 1,000 PSI. Pump flow goes into the main circuit until the pressure reaches the relief valve setting. Then, with the 4-way valve still shifted to a side position, the intensifier can be connected into the same or into some other circuit to produce a flow of 15 GPM at a pressure of 2,000 PSI.

To review the intensifier action: With Section 2 dumped to tank, it becomes a hydraulic motor and mechanically drives Section 1 to twice the pump pressure but with a flow output of only one-half the pump flow.

**FIGURE 3. Higher Ratios.** Greater intensification is possible when using a rotary intensifier having higher displacement in one section than in the other. Intensification will be in the same ratio as the ratio of displacements.

In this example, the rotary intensifier has twice the displacement in Section 2 compared to Section 1. Using the same example of a 30 GPM pump flow at a maximum pressure of 1,000 PSI, this circuit can deliver up to 3,000 PSI but at a reduced flow of 10 GPM. Conversely, if Section 1 were dumped and Section 2 delivers into the load, pressure intensification would be from 1,000 PSI up to 1,500 PSI, the flow from Section 2 would be 20 GPM.

A relief valve should always be used on the pump line. When this gear unit is used as an intensifier, usually no relief valve is needed on either outlet. But when used as a flow divider, each outlet should be protected by a relief valve, to limit the pressure intensification which may occur if one outlet should become unloaded.

**FIGURE 4.** Other Variations. An extreme case is shown here using a four-section flow divider as an intensifier. Each section can either be permanently connected to the outlet or dumped to tank. Three ratios of intensification can be obtained by selectively dumping one, two, or three sections. For example, with Sections 2, 3, and 4 dumped, pump pressure can be intensified to four times relief valve setting. Or, two sections can be dumped and the other two fed into the working circuit.

Since rotary intensifiers are basically gear pumps, they have a maximum pressure rating which must be observed.

**More Information.** For more detailed information on both piston-type and rotary-type intensifiers the reader is referred to the **Womack** textbook "*Industrial Fluid Power - Volume 2*". For more information on rotary flow dividers, see **Womack** textbook "*Industrial Fluid Power - Volume 3*".

Published by:  
**WOMACK EDUCATIONAL PUBLICATIONS**  
**Womack Machine Supply Co.**  
 13835 Senlac Dr.  
 Farmers Branch, TX 75234  
 Tel: 800-859-9801 Fax: 214-630-5314  
[www.womack-educational.com](http://www.womack-educational.com)

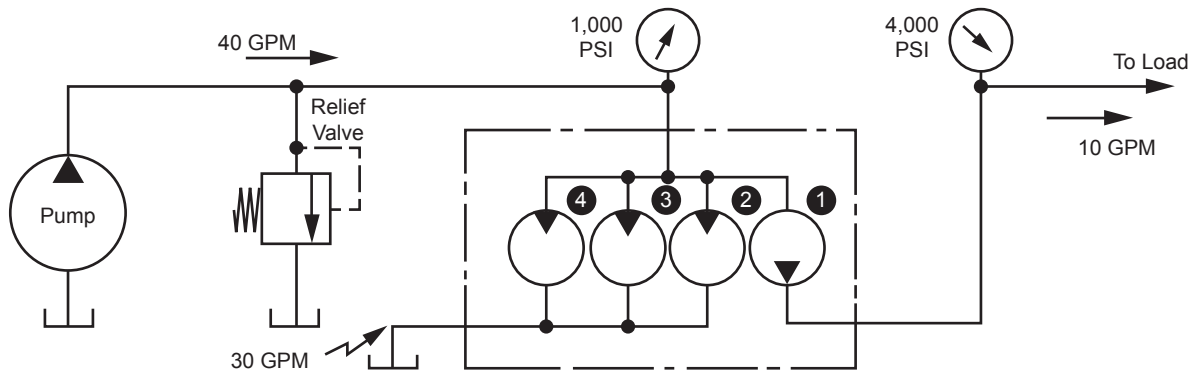

**Figure 4.** Pressure Intensification with a 4-Section Flow Divider.